

LAYING INSTRUCTIONS – LOC-CLICK

JANGAL | Laminate

PREPERATION



We recommend that you use the following tools for installation:

- Vapor barrier
- Impact sound insulation
- saw
- hammer
- tapping block
- spacer blocks
- bending rule
- pencil

Measure the width of the room in advance and calculate the width of the last row of boards.

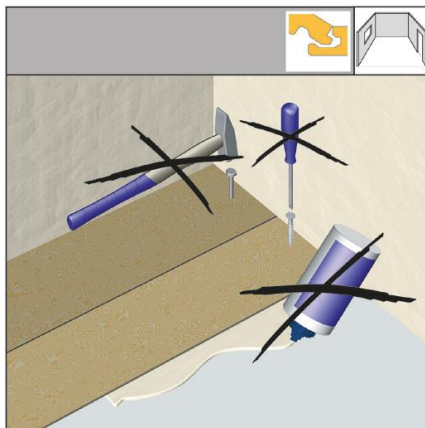

The floor is installed as a floating floor. Only the tongues and grooves are mechanically interlocked.

Boards must not be glued, nailed or otherwise attached to the subfloor.

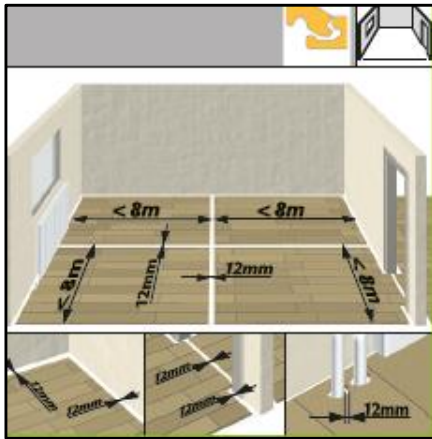

The largest possible continuous installation area is 8 m in the direction of the width of the board and 8 m in the direction of the length of the board.

- Larger areas should be divided by expansion joints of at least 12 mm.
- Expansion can be up to 2 mm/m.
- A minimum distance of 12 mm between the walls all around must be taken into account.
- Expansion joints of at least 12 mm must be provided between the rooms. These expansion joints can be covered with special profiles
- A distance of 12 mm must also be maintained from fixed elements, such as radiator pipes.

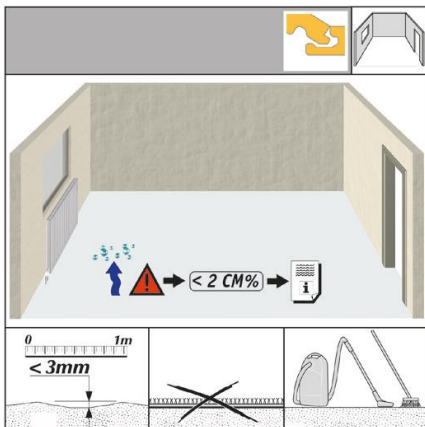

The substrate must be free of cracks, clean, tension/pressure resistant and permanently dry (VOB, part C, DIN 18365). The flatness of the substrate must not vary by more than ± 3 mm over 1 m (DIN 18202).

NOTE: Old coatings must be completely removed from the substrate, as they affect the flatness of the substrate.

Installation on mineral substrates

The most recognized method is the CM method (calcium carbide method):

- Cement screed: 1 week drying/cm, residual moisture: $>2.0\%$.
 - Anhydrite screed: 2 weeks drying/cm, residual moisture: $<0.3\%$.
 - Mastic asphalt: from 18°C
 - Magnesian screed: equilibrium moisture
- Miner. Levelling compounds: according to manufacturer's instructions.

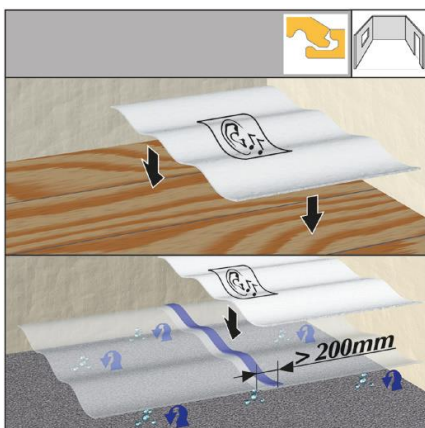

A vapor barrier should be used to protect against rising moisture. It prevents the penetration of rising moisture.

A step insulation must have sufficient pressure stability ($\text{CS} \geq 90$ kPa).

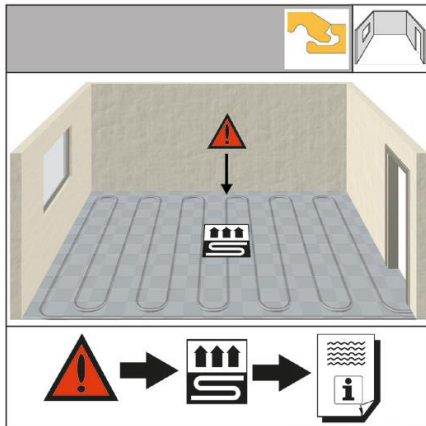

The floor can be installed over a hot water heating system.

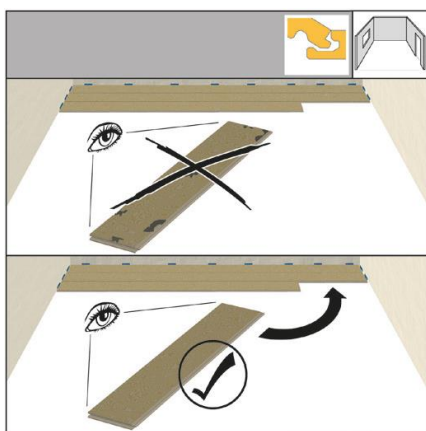

Before installation, check the boards for any defects. Boards with minor damage can be installed in areas where they should be cut anyway.

Installation should only be done in daylight or under adequate lighting, as minor defects may not be detected under artificial lighting.

Faulty installed panels are excluded from claims.

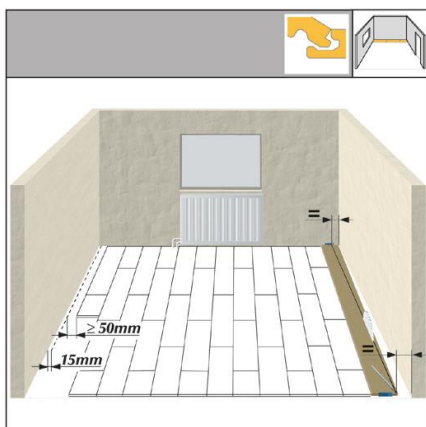

The first and last row of panels must be at least 50 mm wide from the wall. If the wall is not straight, mark the deviations on the first row of panels with a spacer.

Cut the boards to length along the markings. The first row of boards should be cut lengthwise if the last row of boards to the opposite wall is less than 5 cm.

Please note the 15 mm distance to the walls.

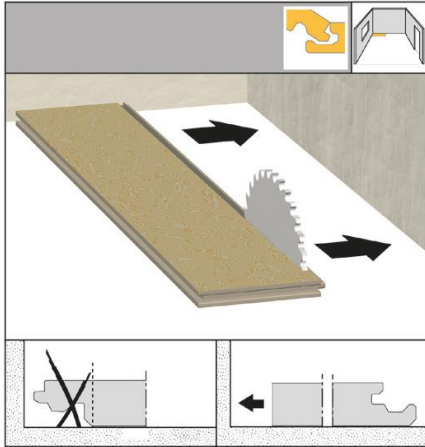

Remove the tongue from the first row of panels and place the trimmed side against the wall.

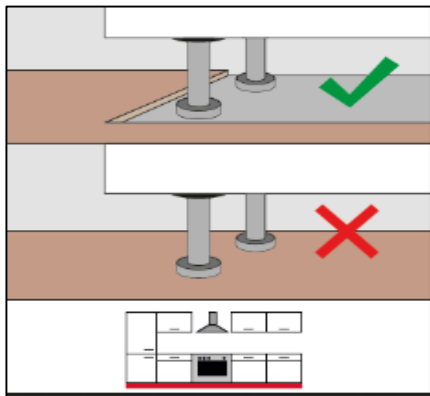

Fitted kitchens and built-in cabinets must be assembled prior to installation. Installation over flooring is not permitted.

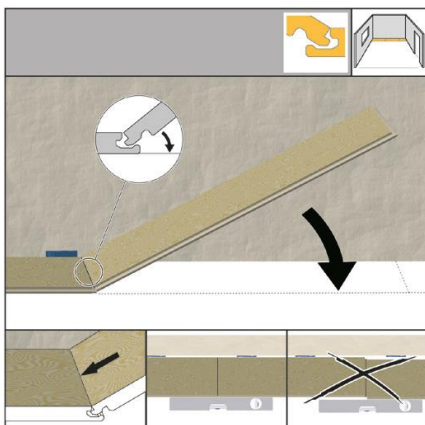

Fit the panels into the previous panel on the front side at a shallow angle of approximately 25°. Make sure that the panels are perfectly aligned with each other.

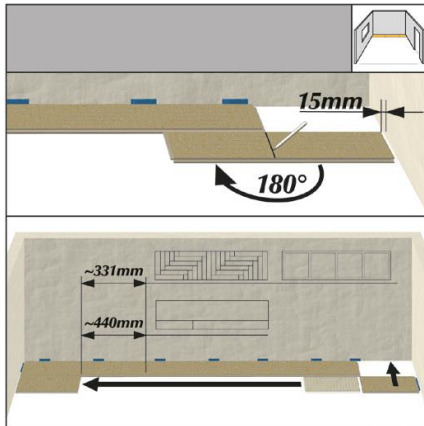

Turn the last board in the row 180° and lay it next to the existing row, decorative side up (take into account the distance from the wall at the end). Then mark the board and saw it.

Always saw from the top of the panel (to avoid chipped edges). Only with an electric jigsaw or a hand-held circular saw, the decorative side should be facing downwards

Start each new row with the remaining piece from the previous row. Please respect the minimum offset.

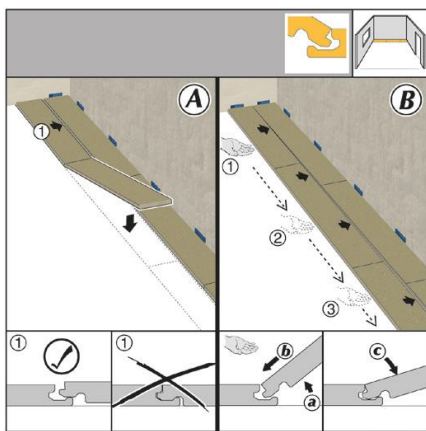

A) Assemble the panels along the entire length of the piece on the short side and at the same time place them only on the cheek of the lower groove of the first row, but don't block them.

B) Assemble the long side of the panels from left to right with the first row in a zip-lock manner to do this:

- a. Lift the panels
- b. Insert the tongue into the groove
- c. Lower the panel

Position the first panel of the second row exactly on the side of the groove of the first row without locking it to the first row. Now place the second panel on the narrow side. Position it using the first row as a stopper and rotate the panel inward.

Continue this process along the entire length of the piece. This results in 2 rows of panels that are simply attached to the long sides but not locked yet (2 mm gap, the second row rests on the groove of the first).

Now start interlocking the 2 rows of panels from left to right lengthwise, like a zipper. To do this, lift the locked row of panels slightly, push the tongue into the groove and lower the panel. Work across the entire length of the room.

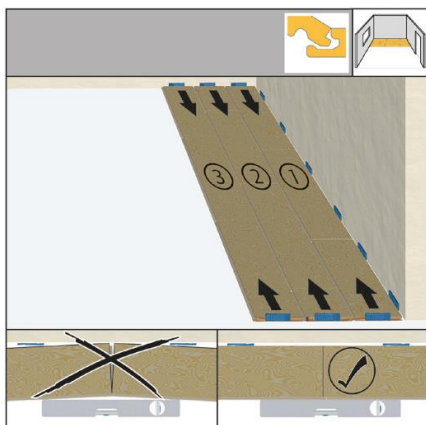

Lay the first 3 rows before positioning them exactly in the room. This ensures a solid bond between the boards. With exact positioning, there will be no unwanted sliding of the boards. The first 3 rows are secured with spacers to prevent the installed area from slipping or shifting.

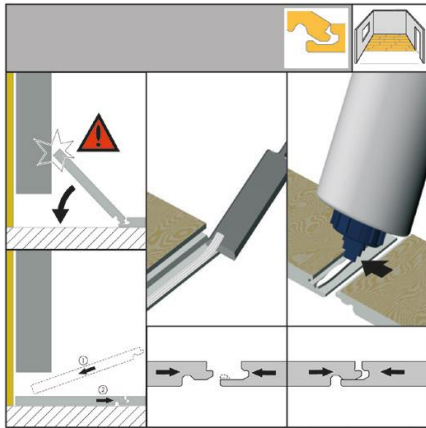

Where pivoting is not possible (e.g., under door frames and radiators), remove the cheek locking pin from the bottom groove using, for example, a chisel.

Glue the groove with D3 glue and push the joint flat.

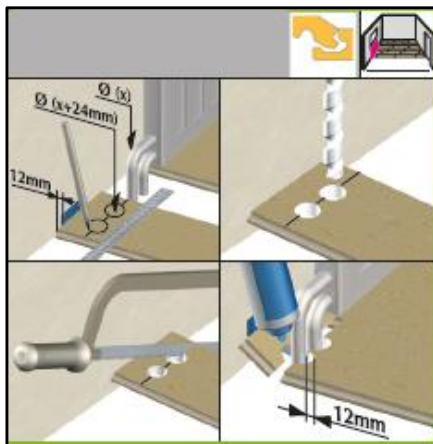

If, for example, heating pipes protrude from the floor, first cut the board to the right length. Then lay the board piece next to the actual location and measure and mark the recesses with the bending rule. Again, don't forget to leave a gap of at least 12 mm around the expansion joint. You can now drill the marked areas. Then saw the board to size. Then place it behind the heating pipe and join it back to the board

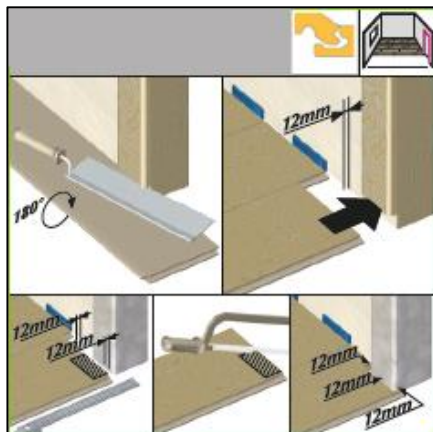

Wooden door frames can be shortened. To do this, place a board against the frame with the decorative side down. Now shorten the door frame with an appropriate saw along the board. Then the board can simply be pushed under the frame with the decorative side up.

For door frames that cannot be shortened, cut the board accordingly and observe the minimum circumferential distance of 12 mm for expansion joints.

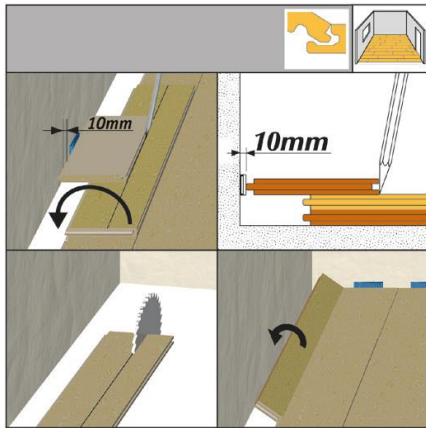

For the last row of panels, the boards must be placed exactly on the second to last row. Using a leftover piece (original width), transfer the distance to the wall to the board. The board is then cut lengthwise. Note the minimum distance.

In order to determine the exact width of the last row of panels, the board must be laid exactly congruent on the second to last row of panels (observe the distance to the wall). Then place a second board with the groove facing the wall on the board to be measured, use it as a ruler and mark it accordingly. Then cut the board lengthwise (observe the minimum distance). Then close the long edge and turn it inwards.

CLEANING AND CARE

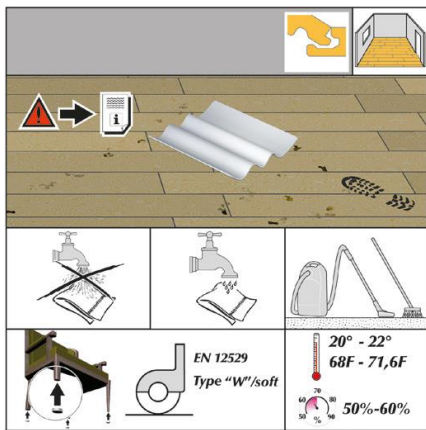

Please do not use wet cleaning and use furniture glides. The recommended room climate must be maintained.

Please also observe the following rules:

- Simply clean the floor daily with a vacuum cleaner or broom.
- Wipe off footprints and dirt with a damp cloth (well wrung out wipes).
- Any normal household cleaner can be used for cleaning - but never abrasive cleaners, waxes or polishes.



Dirt-holding mats in entry areas are essential. Dirt such as fine minerals will damage hard flooring because it acts like sandpaper.

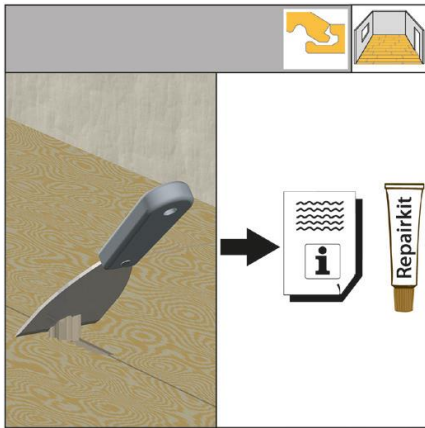

If small damages such as cracks or indentations occur, you can repair them yourself using the color-matched repair kit. This does not diminish the quality of the floor. Larger damages, on the other hand, should be repaired by a professional.